

# TriVista

## Triple Spectrographs and Scanning Monochromators

- Raman Spectroscopy
- Photoluminescence spectroscopy
- No notch or long pass filters required
- Use any excitation laser wavelength or tunable lasers
- Measure as close as  $2\text{cm}^{-1}$  ( $120\mu\text{eV}$ ) of the excitation laser
- High resolution spectroscopy from UV to NIR



# Overview

## most versatile spectroscopy system

TriVista spectrometers are research-grade, triple monochromators and spectrographs offering the highest level of optical performance and versatility for demanding spectroscopic applications.

TriVista systems offer significant advantages for applications requiring the highest resolution and stray light rejection to detect even the smallest energy shifts from the excitation laser line.

Unlike systems that rely on optical filters, such as Raman edge or VHG filters, TriVista systems can adjust to any experimental condition and work at any laser wavelength, even tunable excitation lasers.

TriVista systems are comprised of three spectrometers mounted to a rigid baseplate operating in precise computer-controlled synchronization. Intuitive, powerful software operates each stage independently or together with other stages, allowing TriVista systems to operate as a single, double or triple spectrometer to meet a wide range of experimental requirements.

## Applications

- |   |   |
|---|---|
| <ul style="list-style-type: none"> <li>• Raman Spectroscopy</li> <li>• Low Frequency (THz) Raman</li> <li>• Resonance Raman Spectroscopy</li> <li>• Photoluminescence</li> <li>• Fluorescence</li> <li>• Time-Resolved Spectroscopy</li> <li>• UV, VIS and NIR Raman</li> <li>• Spin-Flip Raman Scattering</li> <li>• Magnetic Raman Spectroscopy</li> <li>• Solar Cell Research</li> </ul> | <ul style="list-style-type: none"> <li>• Quantum Materials</li> <li>• 2D Materials</li> <li>• Nanotubes, Nanostructures, Nanowires</li> <li>• Semiconductors (GaAs, InAs(Sb), GaN, SiC, SiGe)</li> <li>• Pharmaceuticals</li> <li>• Supermolecules</li> <li>• Biomolecules</li> <li>• Amino Acids and Polypeptides</li> <li>• Magnetic Properties of Materials</li> </ul> |
|---|---|

# Key Features and Benefits

Feature	Benefits
Full Wavelength Scanning	<ul style="list-style-type: none"> <li>Operate at any wavelength from UV to SWIR</li> </ul>
Highest stray light rejection	<ul style="list-style-type: none"> <li>No need for Raman edge or notch filters</li> <li>Ideal for multiple excitation wavelength or tunable laser sources</li> <li>Permits UV Raman spectroscopy where no filters are available</li> <li>Superior stray light rejection to <math>10^{-14}</math></li> <li>Allows detection of Raman signal within <math>5\text{cm}^{-1}</math> of the laser line (0.62meV)</li> </ul>
Highest spectral resolution using double and triple additive mode operation	<ul style="list-style-type: none"> <li>Resolves even the finest spectral features</li> <li>300% increase resolution compared to single stage spectrographs</li> <li>High precision grating drive</li> <li>Resolution @532nm = <math>0.13\text{cm}^{-1}</math> (16<math>\mu\text{eV}</math>)</li> </ul>
Subtractive operating mode for highest stray light rejection	<ul style="list-style-type: none"> <li>Detection as close as <math>5\text{cm}^{-1}</math> (0.62meV) of the laser line using CCD, <math>2\text{cm}^{-1}</math> (0.25meV) using PMT</li> <li>No need for edge/notch filters</li> <li>Holographic Gratings: operation in both additive and subtractive modes</li> </ul>
Multiple Configurations/Versatility	<ul style="list-style-type: none"> <li>Operate as triple, double or single spectrometers</li> </ul>
Multiple entrance and exit ports	<ul style="list-style-type: none"> <li>Enables multiple experiments using large range of available accessories and detectors</li> </ul>
Highest sensitivity and performance camera options (back-illuminated, deep-depleted, HR silicon and LN cooled cameras, ICCDs for high time resolution)	<ul style="list-style-type: none"> <li>Almost 100% sensitivity from VIS to NIR wavelength range</li> <li>75% QE at 1000nm</li> <li>&lt; 1ns time resolution</li> <li>Use of LN-cooled CCD cameras for highest measurement sensitivity</li> </ul>
Simple Operation and powerful software VistaControl	<ul style="list-style-type: none"> <li>Convenient and easy configuration of operating modes and configurations with software control</li> </ul>
Exclusive enhanced aluminium coating providing 3-7% more reflectivity per mirror surface than conventional coatings	<ul style="list-style-type: none"> <li>Higher throughput resulting in superior detection capabilities.</li> <li>Optional silver provides 98% reflection from 400 nm to &gt; 2.2 <math>\mu\text{m}</math></li> </ul>
Integrated operation through intuitive, yet powerful software interface	<ul style="list-style-type: none"> <li>Easy experimental set-up, switching quickly between additive and subtractive modes owing to faster results</li> </ul>

# Featured Applications

## 2D Materials

2D research materials explores their fundamental properties and new devices, as well as, novel van der Waals heterostructures obtained from stacking 2D graphene or materials from the class of transition metal dichalcogenides. Raman spectroscopy plays a fundamental role in the characterization of 2D materials identifying the number of layers, measuring defect concentration, deducing structure, and orientation of layers or observing their chemical environment. Trivista allows for measurements of all aspects of 2D materials from basic Raman and PL signatures to low-frequency shear modes that are important to understanding the properties of layers of 2D materials.

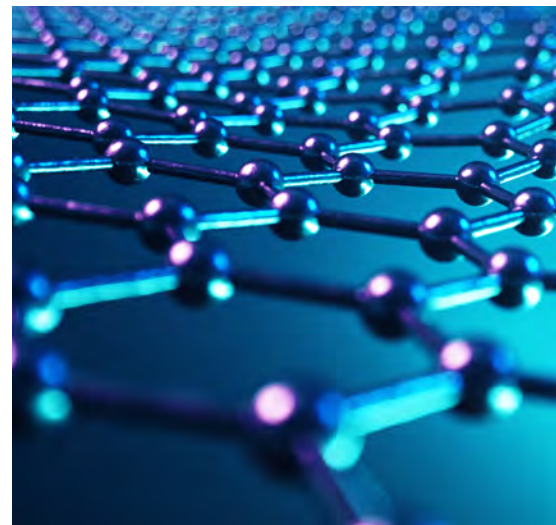

## Quantum Dots

Quantum dots find wide applications in physical and life science such as the development of new light sources and detectors, enhancing materials and devices such as solar cells, drug delivery and biomedical diagnostics. Spectroscopy is fundamental to understanding and characterizing quantum dots, for example probing their electronic structure by photoluminescence or the atomic structure and purity using Raman spectroscopy.

## Solar Cells and Perovskites

Future developments in clean energy will be based on the research of new materials for solar cells. Perovskites and nanotechnologies such as quantum dots, are being researched for their potential of increasing efficiency and reducing cost of solar cells for photovoltaics. Development of these new photovoltaic materials requires use of sensitive and high resolution spectroscopies, such as photoluminescence to determine electronic structure, or Raman for measuring material quality, influences of the environment, and the role of defects and disorder.

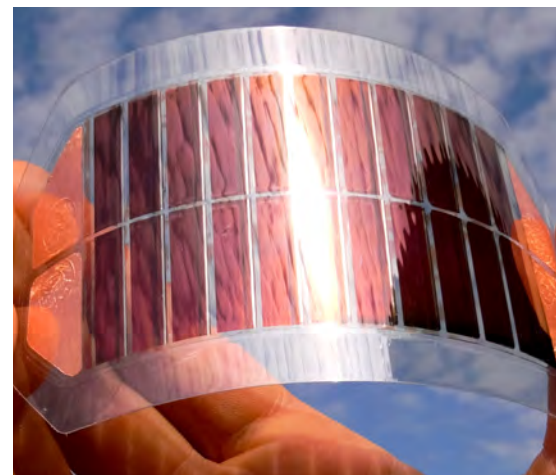

## Low frequency/THz Raman

Measurements of the THz or low frequency Raman region below  $150\text{cm}^{-1}$  require a level of stray light rejection that can't be provided by standard Raman filters. Subtractive mode on TriVista systems enables observations as close as  $1\text{-}2\text{cm}^{-1}$  to the laser line and can easily be adapted to different excitation wavelength. Applications include the observation of shear modes of 2D materials or investigations of the conformational state of proteins.

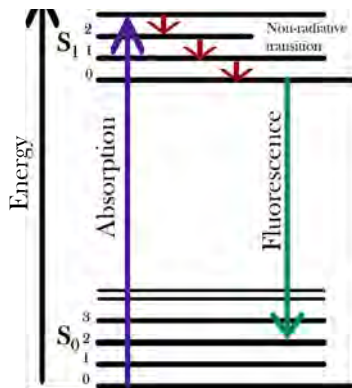

## Photoluminescence

Photoluminescence spectroscopy is an important technique to characterize materials by probing their electronic structure. Photoluminescence gives insights into the size of bandgaps, element composition, impurity concentration, material quality, charge diffusion, and recombination that are important to determine the efficiency of a material in photonic devices.

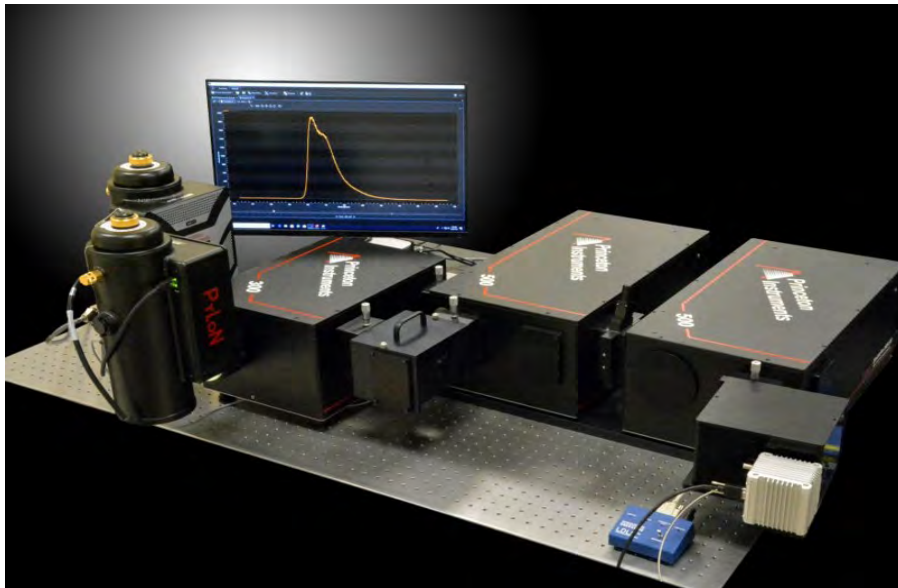

Multi-stage spectroscopy system for PL excitation measurements of materials for renewable energy research and solar cells. The first two stages operate as tunable bandpass filter in subtractive mode to select a small wavelength band from a continuous Xe light source. PL signal from the sample chamber is collected in the third stage.



# Benefits

## Versatile operation

TriVista spectroscopy systems can be operated as single, double, or triple spectrometers. Exit ports can be configured with cameras, as exit slits for operation with single channel detectors, or use as high performance bandpass filters.

The intuitive software interface and high precision mechanics allow change of configurations through convenient computer control.

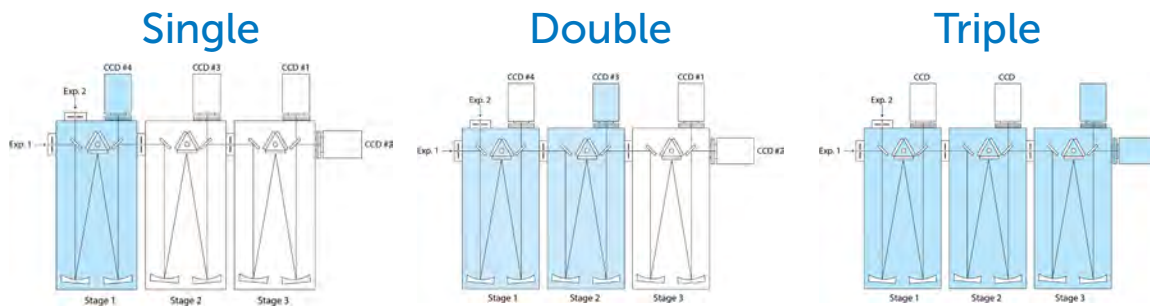

## High Spectral Resolution

- Add the diffractive power of multiple spectrometer stages
- Up to 3x higher resolution compared to single stage system

*The fine structure of a spectral line is not resolved in a single stage system (red line) and is clearly resolved by a triple stage TriVista system*

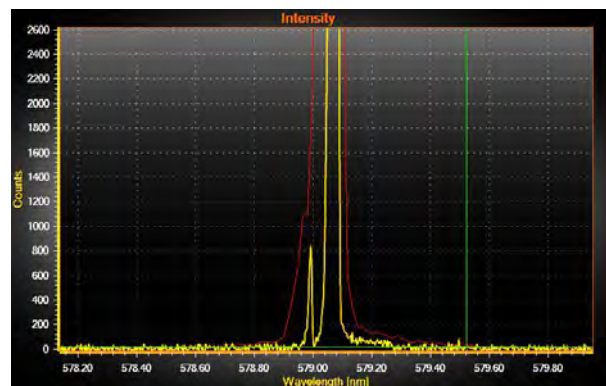

## Measure close to the laser line

- Stray light rejection of TriVista triple spectrometers in subtractive mode
- Detection of low frequency Raman signals as close as  $5\text{cm}^{-1}$  ( $0.62\text{meV}$ ) of the laser line (532nm, subtractive mode, CCD detector)

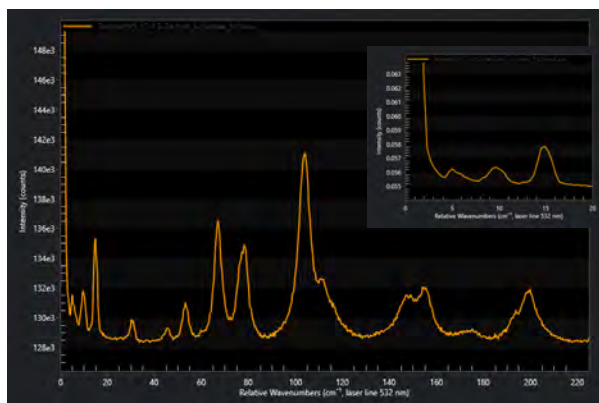

*Low energy Raman spectrum of L-Cystine resolving bands as low as  $5\text{cm}^{-1}$*

## No optical filters needed Superior filter performance at any wavelength

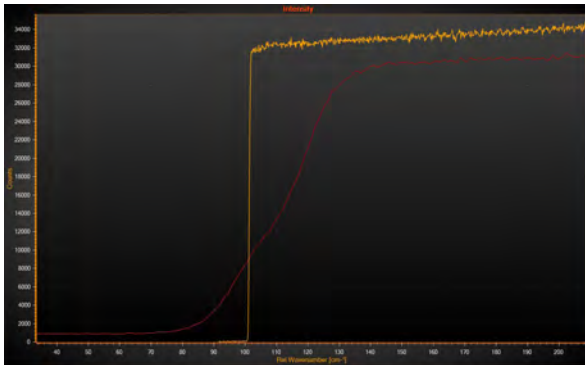

- Operate at any wavelength from UV-SWIR
- No edge, notch, or other filter needed
- Use any excitation laser
- Adjust to multiple lasers using triple grating turrets
- Sharper and higher quality absorption edges than state-of-the-art Raman filters.

*Filter Comparison: Yellow = TriVista cut-off, Red = Raman Edge Filter cut-off. Note how steep the cut-off slope is for the TriVista system compared to the edge filter*

## Unbeatable Precision and Accuracy

- AccuDrive technology for precision movement
- Ultra-high wavelength precision and reproducibility
- Rigid construction provides rock solid accuracy, repeatability, and stability

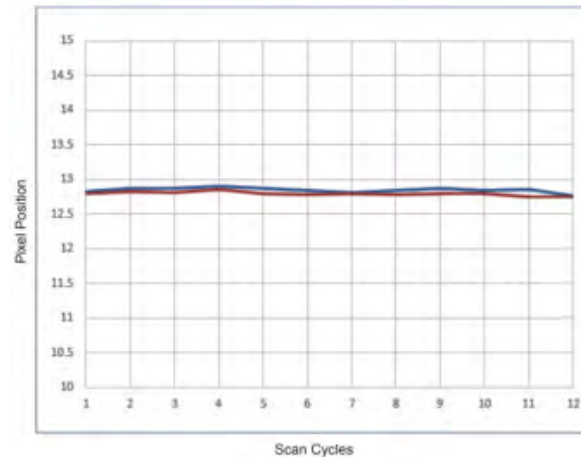

At the heart of TriVista is the AccuDrive system for positioning grating drives in each stage with exceptional accuracy and repeatability. This graph shows a cycle test where the grating stage is scanned repeatably between zero and 546nm and 1100nm while recording the exact position at each step.

# Additive Mode

## For High Resolution

Additive mode increases spectral resolution by combining the dispersive power of multiple spectrometer stages. In this operation mode the gratings in each stage rotate synchronously adding dispersion to each other. Depending on system configuration, additive mode can be configured for measurements with only two or all three TriVista stages.

When using three TriVista stages in additive mode (shown in the figure below), the spectral resolution increases by 3x compared to a single spectrometer stage. The precise control of the grating movement allows easy adaption to experimental conditions such as changing the excitation laser wavelength.

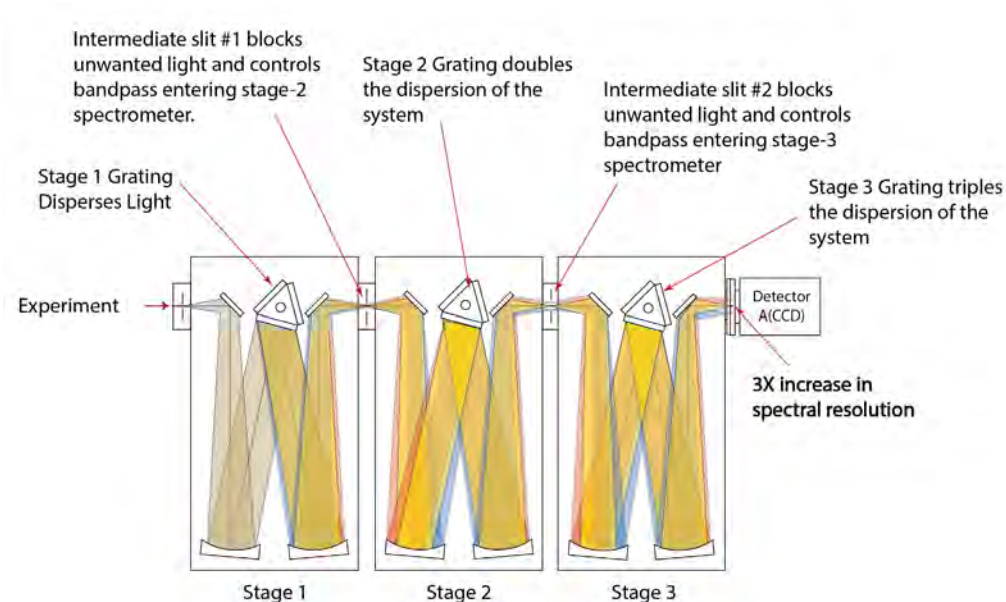

## Highest Resolution from UV to NIR

Dispersive spectrographs achieve high resolution with a combination of parameters including groove density of diffraction gratings. However, high groove density gratings for highest resolution are limited to operation at UV-VIS wavelength due to limits of rotating the gratings.

Additive mode on TriVista systems expands the high dispersion range by combining the power of several lower groove density gratings so high resolution can be achieved at SWIR and Telecom wavelength as well.

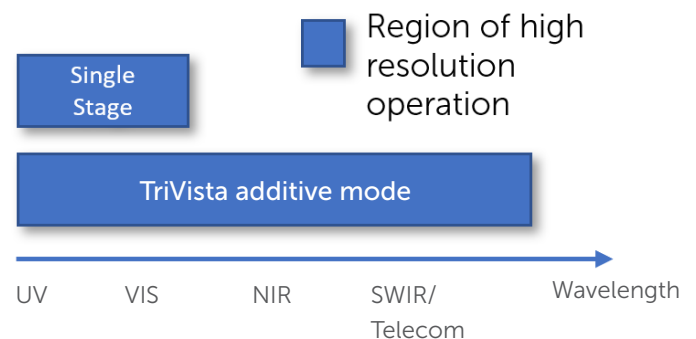



# Subtractive Mode

For Measuring Close to the Laser Line/

High Stray Light Rejection

Subtractive mode increases stray light rejection of the TriVista system which is necessary for measurements of small energy shifts from the excitation laser line. In subtractive mode, the grating in stage two rotates opposite to the grating in stage one, counteracting its dispersive effects. Adjusting the slit width between first and second stage selects a wavelength band that is passed along to the third stage for detection. Light with wavelength outside of the selected band is strongly suppressed.

When using CCD cameras for detection, spectral measurements to  $<5\text{cm}^{-1}$  ( $0.62\text{meV}$ ) can be realized.

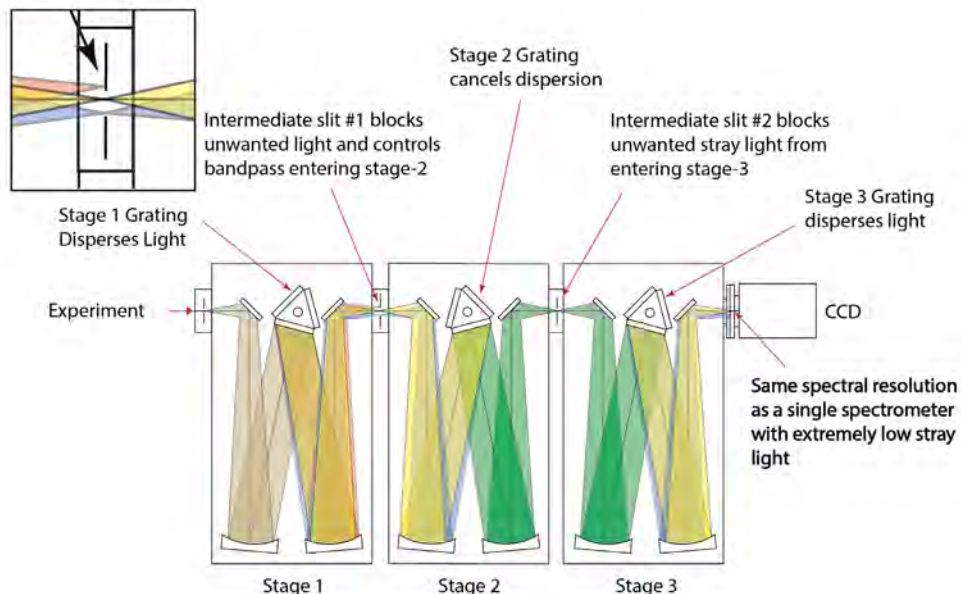

## Grating selection for additive and subtractive modes

Each TriVista stage contains triple grating turrets for optimizing measurements based on operating mode, desired spectral resolution, and wavelength band of measurement.

Both TriVista operating modes can be achieved using ruled as well as holographic gratings. The ultra-precise, independent grating drive systems allows for any grating to be used in any mode of operation. While there are no restrictions for holographic gratings, we recommend selection of additive or subtractive dispersion for gratings in stage 1 and 2 at time of order to optimize the grating blaze direction for highest light throughput. You could, however, have one grating set configured for additive mode and a second grating set configured for subtractive mode.

# Highest Sensitivity and Performance

## High throughput optics

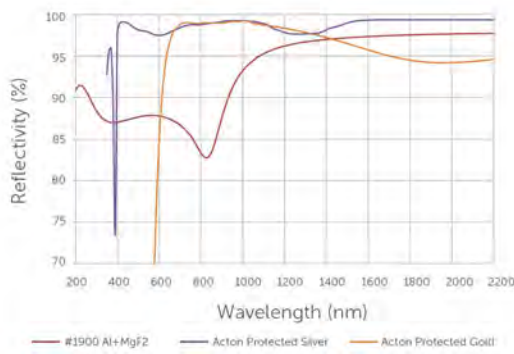

- Teledyne Princeton Instruments' enhanced reflective coatings
- Superior light throughput and greater overall system efficiency
- Enhanced aluminium and silver coatings
- Broad high performance wavelength coverage

## Detectors

### PyLoN

- Liquid nitrogen cooled CCD camera
- Highest sensitivity for detecting ultra-weak PL or Raman signals
- eXcelon® technology, anti-fringing and increased UV-NIR sensitivity
- Perfect for single molecules and low excitation power measurements



### Pylon IR and NIRvana

- NIR-II/SWIR and telecom wavelength detection (900-2200nm)
- InGaAs array with high performance TE-cooling or LN cooling
- Advanced cold shield design
- Ultra-low thermal noise, high sensitivity

### PI-MAX4

- Intensified CCD and ultra-sensitive emICCD cameras
- Time resolved spectroscopy
- <1ns time resolution
- Ultrafast transient events such as charge carrier diffusion and recombination in perovskites for photovoltaic applications.



# Accessories

## Stokes and Anti-Stokes

Stokes/Anti-Stokes Raman spectroscopy is an important technique for measuring temperature in materials by comparing the intensity of Raman bands at equal energy above and below the laser excitation line. The TriVista Stokes/Anti-Stokes accessory is designed specifically for simultaneous measurements of both sides of the laser line, down to the low frequency region.

- Inserted between stage 2 and stage 3
- Precision mechanics for accurate positioning of baffle to block Rayleigh scatter
- Multiple stop settings/baffle width

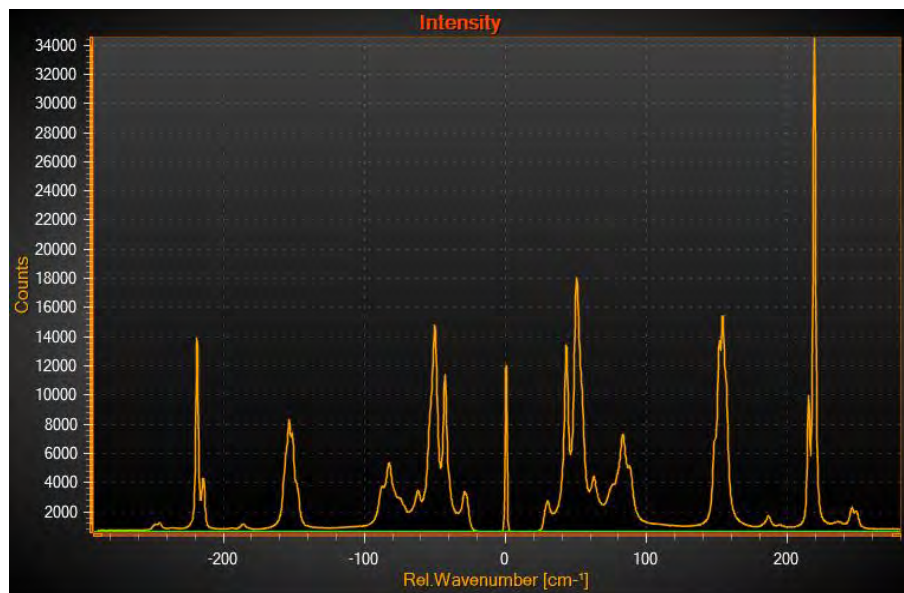
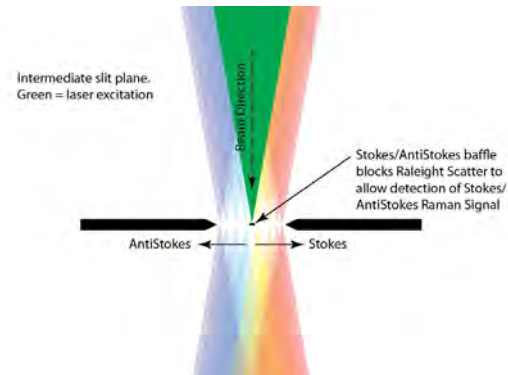

Stokes/Antistokes Raman spectrum of sulfur. The residue Rayleigh scattering line is visible in the center. Raman bands at higher and lower energies are visible clearly even in the low frequency region  $<100\text{cm}^{-1}$

# TriVista Models

## TriVista TR555

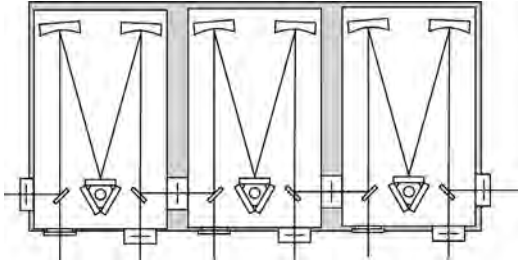

- Three 500mm focal length stages
- Larger input aperture for improved light collection
- Excellent high resolution and stray light rejection

## TriVista TR557

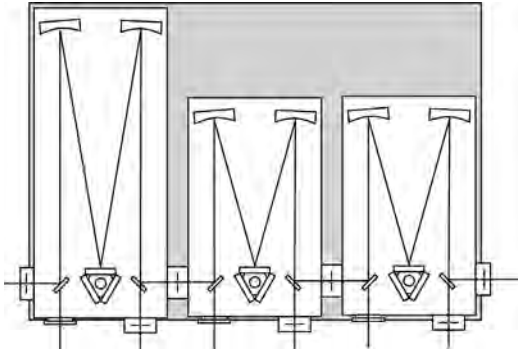

- Two 500mm + one 750mm focal length stages
- Larger input aperture for good light collection
- Highest resolution in subtractive mode

## TriVista TR777

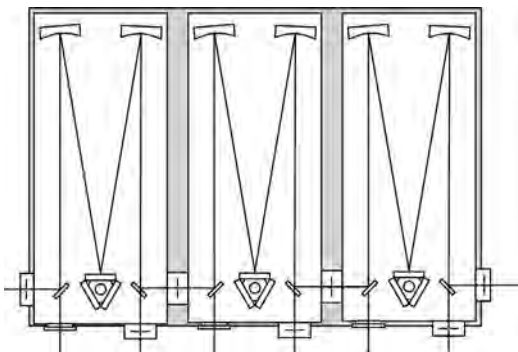

- Three 750mm focal length stages
- Most narrow bandpass filter
- Highest resolution in any operating mode

# Customization

The TriVista is designed by spectroscopists with years of experience creating custom solutions. Our application scientists are eager to discuss your specific experiment needs and suggest the optimum system configuration.

Whether it is the selection of appropriate gratings to optimize spectral resolution and coverage, or the choice of detectors and accessories, you can rely on our team of experts to design the proper system to meet your application requirements.

## Example 1: Raman spectroscopy

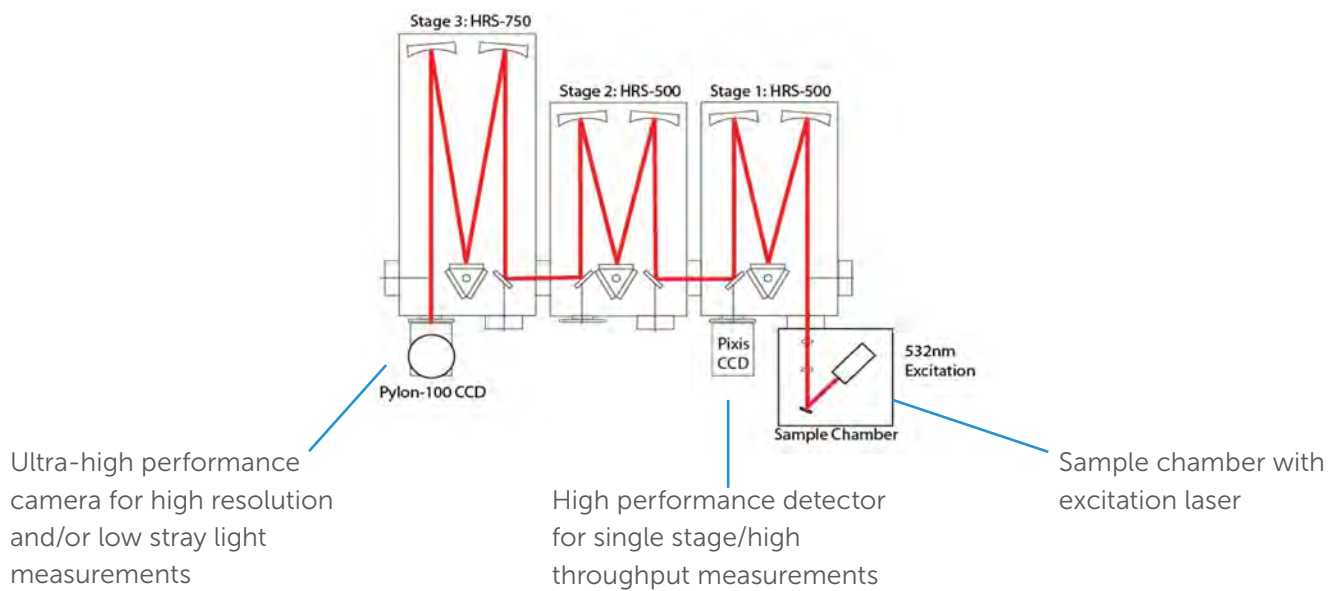

## Example 2: PL excitation

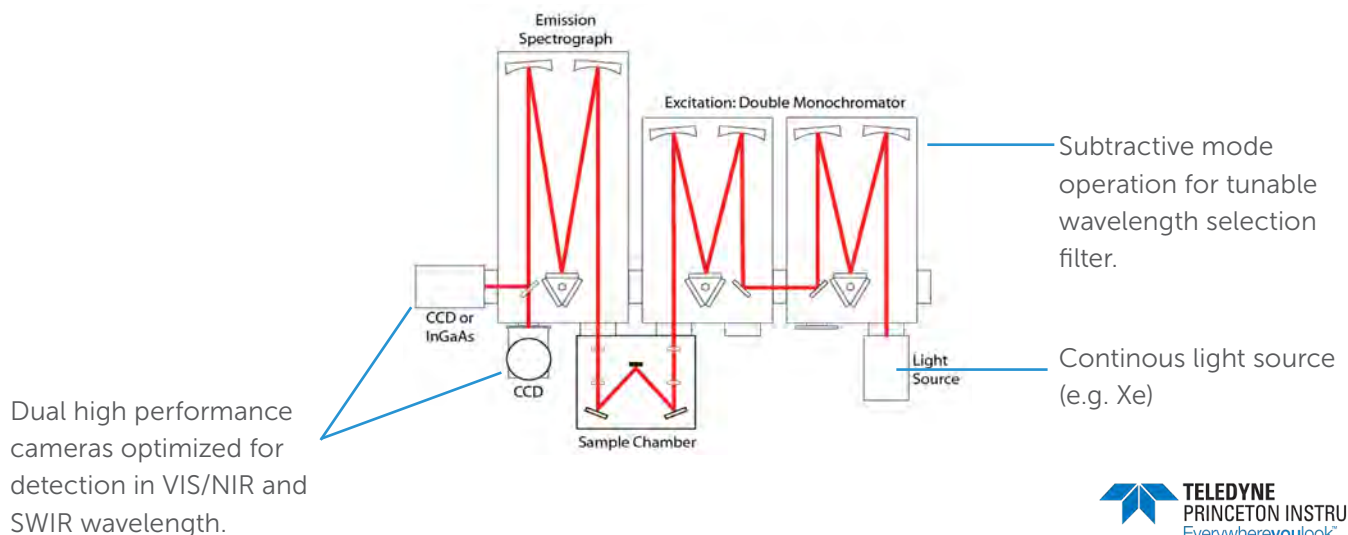



# Powerful Software – VistaControl

Easy and automatic setup and control



VistaControl is a powerful and intuitive software suite for TriVista spectroscopy systems. Experiments are easily accessed by a simple mouseclick with the VistaControl software interface. The powerful software gives full control over the spectrograph calibration, grating selection, and scanning, as well as operation of Teledyne Princeton Instruments CCD detectors or the SpectraHub readout system for single point detectors.

## VistaControl features:

- Easy TriVista setup with graphical user interface
- Full scan control and data acquisition
- Computer-controlled selection of additive or subtractive modes
- Controls the TriVista system as a triple, double or single spectrometer
- Allows saving multiple configurations for later use and quick change of configuration
- Works with all Teledyne Princeton Instruments cameras and data acquisition systems
- Options for stage control and hyperspectral sample mapping

# Specifications\*

Mode of Operation: Subtractive

PyLoN Camera with 20 $\mu$ m Pixel (PyLoN 100 or 400)

Gratings in Subtractive 2nd Stage	Grating in Spectrograph Stage	Total CCD coverage	Total CCD coverage	Bandwidth per 20 $\mu$ m CCD pixel	Bandwidth per 20 $\mu$ m CCD pixel	Min. Distance to Rayleigh line
(l/mm)	(l/mm)	(cm <sup>-1</sup> )	(nm)	(cm <sup>-1</sup> )	(nm)	(cm <sup>-1</sup> )
900	900	860	25	1.445	0.036	12
900	1800	550	10.5	0.6	0.018	10
1800	1800	370	10.5	0.6	0.018	8
1800	2400	370	10.5	0.4	0.011	4

Mode of Operation: Additive

PyLoN Camera with 20 $\mu$ m Pixel (PyLoN 100 or 400)

Gratings in Subtractive 2nd Stage	Grating in Spectrograph Stage	Total CCD coverage	Total CCD coverage	Bandwidth per 20 $\mu$ m CCD pixel	Bandwidth per 20 $\mu$ m CCD pixel	Min. Distance to Rayleigh line
(l/mm)	(l/mm)	(cm <sup>-1</sup> )	(nm)	(cm <sup>-1</sup> )	(nm)	(cm <sup>-1</sup> )
900	900	370	10.5	0.44	0.015	150
1800	1800	160	4	0.18	0.005	125
1800	2400	120	3	0.15	0.004	100

Mode of Operation: Additive

Detector Used: Single Point Detector

Gratings in Subtractive 2nd Stage	Grating in Spectrograph Stage	Resolution	Resolution	Min. Distance to Rayleigh line
(l/mm)	(l/mm)	(cm <sup>-1</sup> )	(nm)	(cm <sup>-1</sup> )
900	900	0.5	0.015	6
1800	1800	0.3	0.005	3
1800	2400	0.2	0.004	2

Mode of Operation: Additive

Detector Used: Single Point Detector

System	TriVista 555		TriVista 557		TriVista 777	
Mode	additive	subtractive	additive	subtractive	additive	subtractive
Focal Length (mm)	1.500	500	1.750	750	2.250	750
No. of Mirrors	10	10	10	10	10	10
No. of Gratings	3	3	3	3	3	3
Grating Size (mm)	64 x 84	64 x 84	64 x 84	64 x 84	64 x 84	64 x 84
Transmission (%) (92% per mirror & 70% per Grating)	15	15	15	15	15	15
Aperture	F/6.5	F/6.5	F/9.7**	F/9.7**	F/9.7	F/9.7
Resolution (nm) 1800 gr/mm, 10 $\mu$ m slits, at 500 nm)	0.005	0.015	0.0046	0.010	0.0033	0.010
Resolution (cm <sup>-1</sup> ) 1800 gr/mm, 10 $\mu$ m slits, at 500 nm)	0.21	0.6	0.17	0.4	0.13	0.4
Weight	225 lbs (102 kg)		250 lbs (113 kg)		300 lbs (136 kg)	
Facilities	110 VAC at 3 Amps max					

\*\*F/6.5 using 1<sup>st</sup> and/or 2<sup>nd</sup> stage only

\*All specifications are subject to change

# Who We Are



**TELEDYNE TECHNOLOGIES**  
Everywhereyoulook™

**3000+**  
employees worldwide

When you partner with Teledyne Princeton Instruments, you become part of a world-class organization with diversified technologies and capabilities.

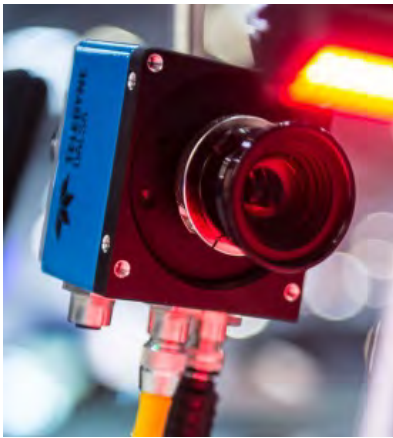

**Machine Vision**



**Medical and Life Sciences**

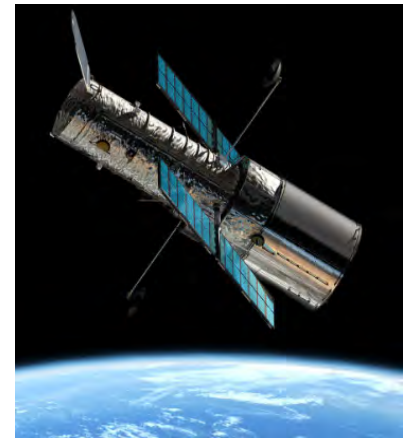

**Aerospace & Defense**



**Scientific**



**Semiconductors**



**Geospatial**

# TriVista

## Unmatched Performance



Contact your local Teledyne Princeton Instruments representative for additional information.

### Teledyne Princeton Instruments – USA

Tel: +1 609.587.9797

[pi.info@teledyne.com](mailto:pi.info@teledyne.com)

### China

Tel: +86 157 2153 5343

[pi.info.china@teledyne.com](mailto:pi.info.china@teledyne.com)

### France

Tel: +33.1.70.38.19.00

[EVR@teledyne.com](mailto:EVR@teledyne.com)

### Germany

Tel: + 49 (0) 89-660 779 3

[pi.germany@teledyne.com](mailto:pi.germany@teledyne.com)

### Japan

Tel: +81.3.6709.0631

[PI.Nippon@teledyne.com](mailto:PI.Nippon@teledyne.com)

### United Kingdom

Tel: +44 (0) 7810 835 719

[pi.info@teledyne.com](mailto:pi.info@teledyne.com)

**LEARN MORE about TriVista:**  
[www.princetoninstruments.com/trivista-family/trivista](http://www.princetoninstruments.com/trivista-family/trivista)

*Use and Disclosure of Data Information contained herein is classified as EAR99 under the U.S. Export Administration Regulations. Export, re-export or diversion contrary to U.S. law is prohibited.*



**GET IN TOUCH** to find out more  
[www.princetoninstruments.com](http://www.princetoninstruments.com)

Rev A1-07222021

 **TELEDYNE  
PRINCETON INSTRUMENTS**  
Everywhere you look™